



THE IPAD PROJECT

THE IPAD IN THE FILM
CLASSROOM
DIRECTING

PRE-PRODUCTION

- Aaron Goulding, Erin Alcock, and Jane Costello
- 18 Directing students received iPads loaded with apps
- Textbooks provided
- Students interviewed and given questionnaires



Dropbox

kindle



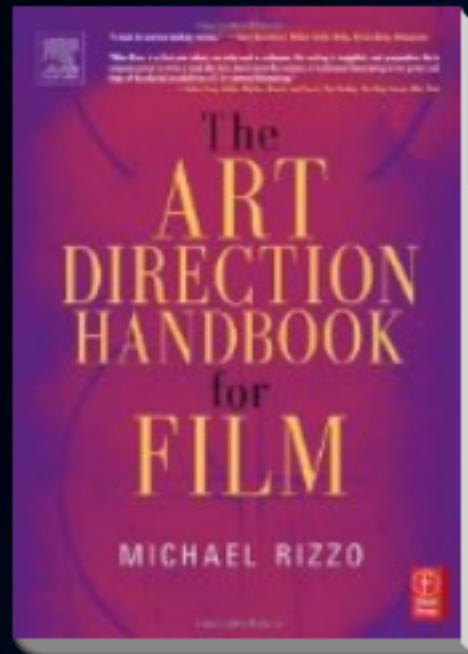

Sample

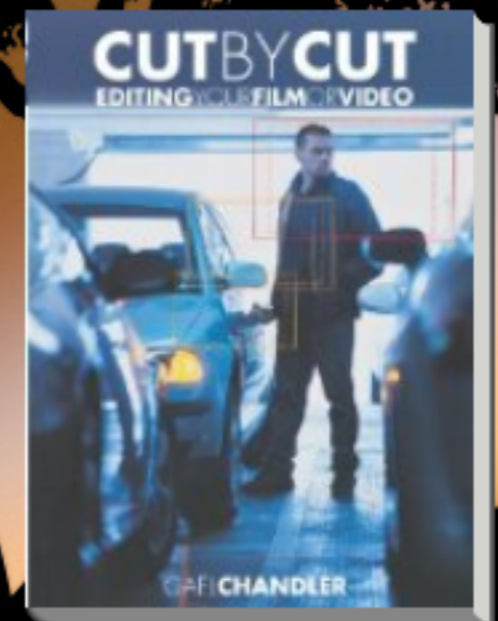
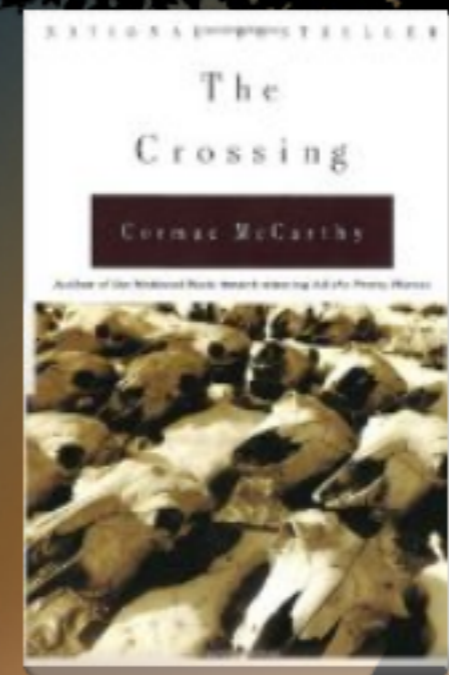
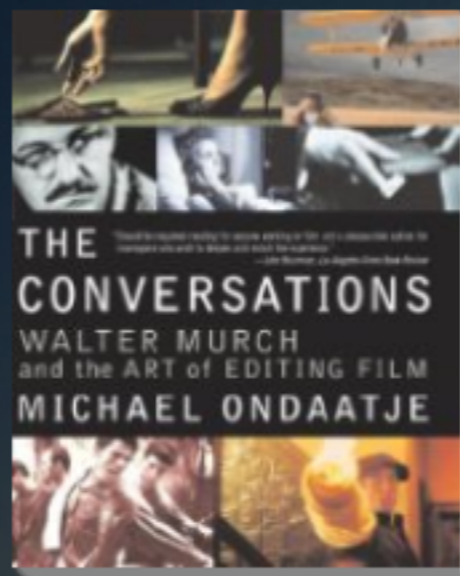
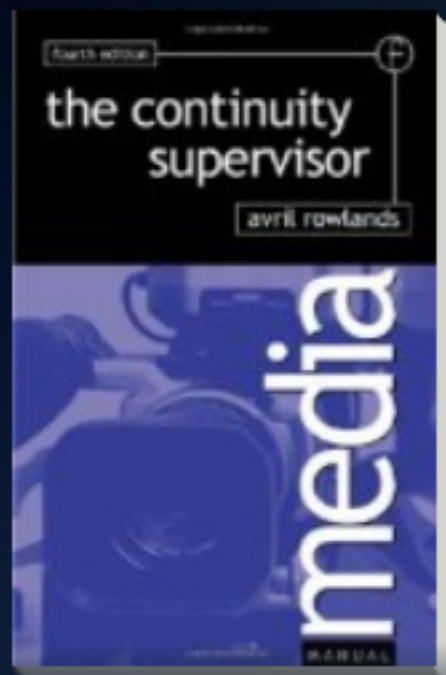
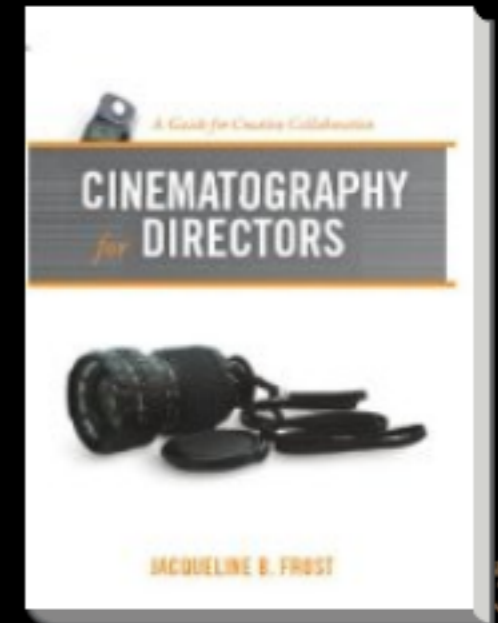
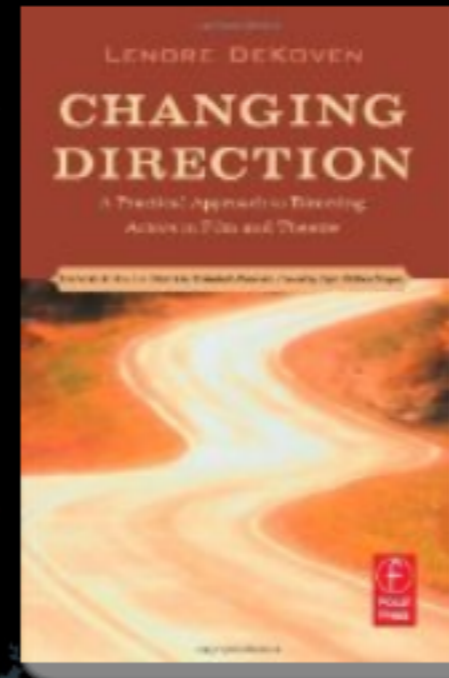
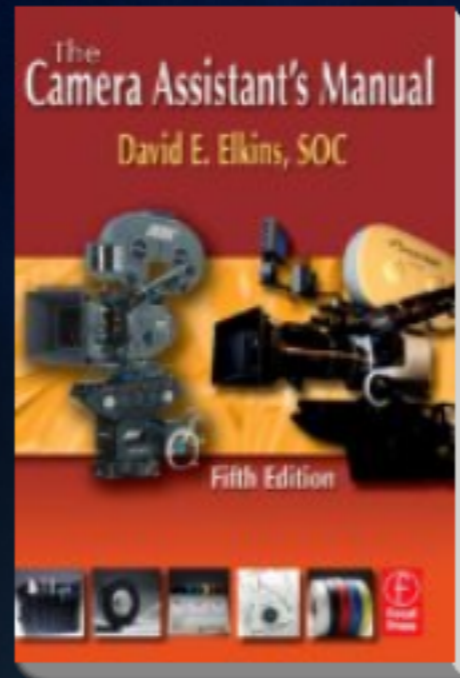

FOURTH EDITION

VIDEO PRODUCTION

HANDBOOK

GERALD MILLERSON
JIM OWENS



FOURTH EDITION

Copyrighted Material





DIRECTING ACTORS

Creating
Memorable
Performances for
Film and
Television

BY
JUDITH WESTON

Film Production Terms

Add to Favorites

Email Definition

Search

A

A

A Wrap

B

A-Wind

D

A.D.R.

F

A.S.A.

H

A/B Printing

J

A/B Rolls

L

AC

M

N

ADC

O

P

ADR

Q

R

ASA

S

T

Above the Line

U

V

Academy Aperture

W

X

Academy Leader

Y

Z

A Wrap

What to say when you are done shooting, either for the day, at that particular set, or on the entire film. Usually if it's not the final shoot you would say you are just going to 'wrap for the day.'



All



Random



Recents



Favorites







Calendars

Invitations (0)

Day

Week

Month

Year

List

Search

December-2011

Sun 27	Mon 28	Tue 29	Today 30 Nov	Thu 1	Fri 2	Sat 3
<ul style="list-style-type: none"> Claritin Banners 8:00 	<ul style="list-style-type: none"> Claritin Meeting with Kat 13:00 Banners 18:30 	<ul style="list-style-type: none"> Claritin Lunch at Pantry 13:00 	<ul style="list-style-type: none"> Claritin 	<ul style="list-style-type: none"> Pay Day Claritin Depart for Hong... 9:00 Arrive NJ 11:00 2 more... 	<ul style="list-style-type: none"> Dorsett Regency Hotel Claritin Arrive Hong Ko... 20:25 	<ul style="list-style-type: none"> Hong Kong Bus Tour Dorsett Regency Hotel Hong Kong Claritin
4	5	6	7	8	9	10
<ul style="list-style-type: none"> Hong Kong Bus Tour Dorsett Regency Hotel Hong Kong Claritin 2 more... 	<ul style="list-style-type: none"> Dorsett Regency Hotel Hong Kong Claritin Tai Chi 8:00 Disneyland 23:00 	<ul style="list-style-type: none"> Hong Kong Royal Park Hotel Claritin Hong Kong 2 more... 	<ul style="list-style-type: none"> Conference Royal Park Hotel Claritin Hong Kong Tai Chi 8:00 	<ul style="list-style-type: none"> Royal Park Hotel Claritin Hong Kong French 19:00 	<ul style="list-style-type: none"> Royal Park Hotel Claritin Hong Kong 2 more... 	<ul style="list-style-type: none"> Royal Park Hotel Claritin Hong Kong Clockenflap 12:00 Cantonese Opera 19:15
11	12	13	14	15	16	17
<ul style="list-style-type: none"> Hong Kong Royal Park Hotel Claritin Depart Hong... 11:25 3 more... 	<ul style="list-style-type: none"> Claritin 	<ul style="list-style-type: none"> Leila to Dr. Mit... 13:00 Alligator Man... 19:00 	<ul style="list-style-type: none"> Alligator Man... 19:00 	<ul style="list-style-type: none"> Pay Day Alligator Man... 19:00 French 19:00 	<ul style="list-style-type: none"> Alligator Man 	<ul style="list-style-type: none"> Alligator Man Messiah 19:00
18	19	20	21	22	23	24
<ul style="list-style-type: none"> Alligator Man Nutcracker 14:00 				<ul style="list-style-type: none"> French 19:00 		
25	26	27	28	29	30	31
				<ul style="list-style-type: none"> Pay Day 		

Today

2010

2011

Jan

Feb

Mar

Apr

May

Jun

Jul

Aug

Sep

Oct

Nov

Dec

2012





Search All Inboxes

Aaron Goulding

Sunday

To Article

Hey Jamie, Didn't really read through the article, but I thought you might be interested...

Kat Lord

Sunday

To Diaspora Paper

Hey Jamie, Here's where I'm at with the Diaspora paper. Still nothing to defined with...

Matt Grant

Saturday

To Great Big Sea

I agree with jamie, i find it pretty echoey
On Nov 26, 2011 1:07 PM, "Jamie Ski..."

3 >

Celtx Support

Friday

To Celtx Sync

Thanks for using Celtx Sync! The free online Sync service lets you import and export scrip...

service@intl.paypal.com Friday

To You set up an automatic payment...

You set up an automatic payment profile
Transaction ID: 0AH273000W802764...

Celtx Studios

Friday

To Celtx Studios Subscription

This receipt confirms payment for your purchase from Celtx Studios. To contact us,...

Celtx Support

Friday

To Your Celtx Account is Active!

Dear UnderTheBridge, Congratulations, your Celtx account is now active. Celtx Studio Lo...

Facebook

Friday

To Robert Chafe commented on your...

facebookHi Jamie, Robert Chafe commented on your photo. Robert wrote: "love it! what a

From: Wayne Keyser

Details

Sending your pdf file from goodmagic.com

30 November, 2011 1:08

Got your payment - THANKS!

Your pdf file is attached

I will send a follow-up email in a few weeks to make sure you received your item in satisfactory condition. If it's acceptable to you, I will also let you know from time to time about additional supporting material you can access free on my website. You can see the current freebies now at <http://goodmagic.com/dvdx/carny/index.htm>

Have you seen my other "always on sale" items? You can see them <http://goodmagic.com>

Don't miss my NEW podcast about carnival, magic, sideshow and burlesque "BALLYCAST" <http://ballycast.com>

I am always available to answer your questions about this purchase or my other offerings. Please feel free to get in touch at any time.

Thanks again!

**Midway Torture Feats.pdf**

1.9 MB



Updated 2011-11-30 11:20



ANGRY BIRDS HD

Celtx v2.9.1 | Bug fix release

celtx

Desktop

Mobile

Studio

Add-ons

Guides







Seeds

Community

Support

About

Project Templates

-  Film
-  Audio-Visual
-  Theatre
-  Audio Play
-  Storyboard
-  Comic Book
-  Novel

#1 choice for media pre-production.

Celtx is the world's first all-in-one media pre-production system. It replaces 'paper & binder' pre-production with a digital approach that's more complete, simpler to work with, and easier to share.

Download Celtx

Free Desktop Software
Mac OS X English (38.2MB)

[Other languages and systems](#)

Download Celtx Plus

Includes Add-Ons | \$14.99
Mac OS X English (40.7MB)

[Other languages and systems](#)

Overview

Features

Screenshots

Release Notes

Donate - Against Malaria



UNDER THE BRIDGE

celt

INT. BAR - NIGHTTIME

Josh and sarah are shown sitting at a bar drinking by themselves separately. Across from him is the back of the bar which has a large mirror, his reflection is clearly scene. The lighting is in line with traditional dim lighting you would find in a bar. They are surrounded by other couples and groups, they are they only two by themselves at the bar, with a female bartender working behind the bar. They notice each other through subtle glances, checking each other out. Their body language suggests that they are both too timid and shy to approach each other. As Josh is looking at her, his reflection speaks to him, in which he replies as if this is a normal everyday thing. Sarah and Josh are very frantic/flustered when speaking.

"JOSH"
Go talk to her!

JOSH
I can't

"JOSH"
What!?

JOSH
I can't go talk to her

"JOSH"
Why not??

JOSH
...I'm scared...

Intro. The Alligator Man plays the intro. to the song on a cigar box ukulele. We only see his hands and the uke.

EXT. BALLYHOO STAGE. DAY.

The Talker is on the ballyhoo stage with a bullhorn attracting members from the crowd.

LEAD

Born in Alabama from the swamplands
and greed There came a man with a
taste for the green Always lookin'
for the quick scam, always on the
lam He's calculating hit man and
he's always got a plan

INT. SIDESHOW PIT. DAY.

The Talker is inside the tent, as the crowd enters. The camera circles the stage. Rubes are getting their pockets picked.



MASTER:

Born in Alabama from...



MEDIUM CLOSE UP:



WIDE:



VERY WIDE SHOT:



CLOSE UP:

Horn moves into shot



EXTREME CLOSE UP:



VERY WIDE SHOT:

Crowd marches like ro...



MASTER:

or man, he's a con man, try him and see Greased hair, silk shirt and a gold set of
He's a wizard with a slight of hand He

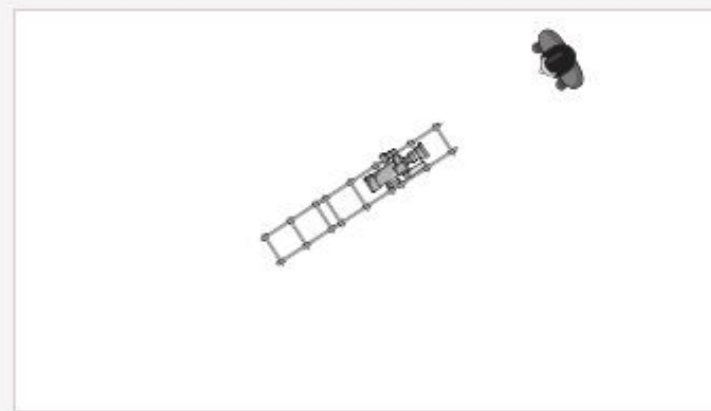
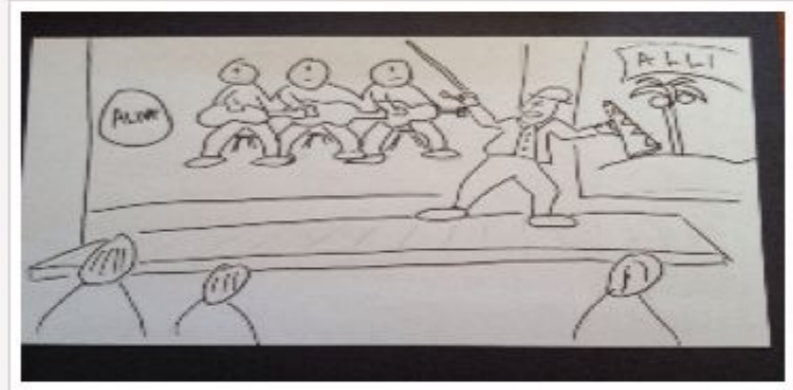

IDE:

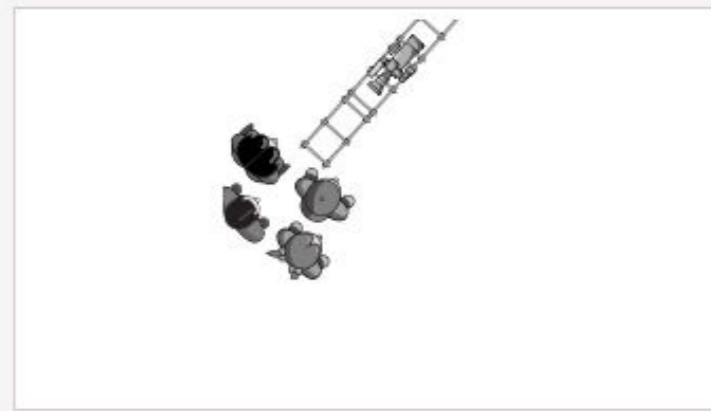
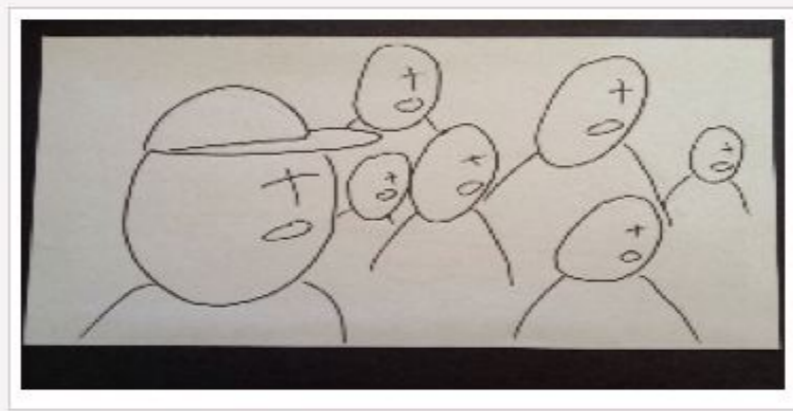

TAWAY:

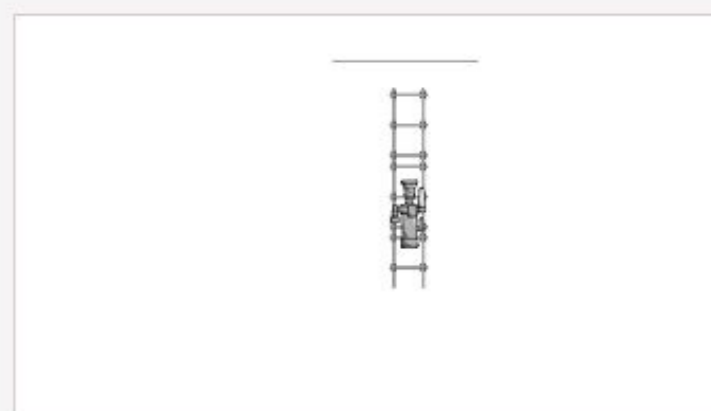
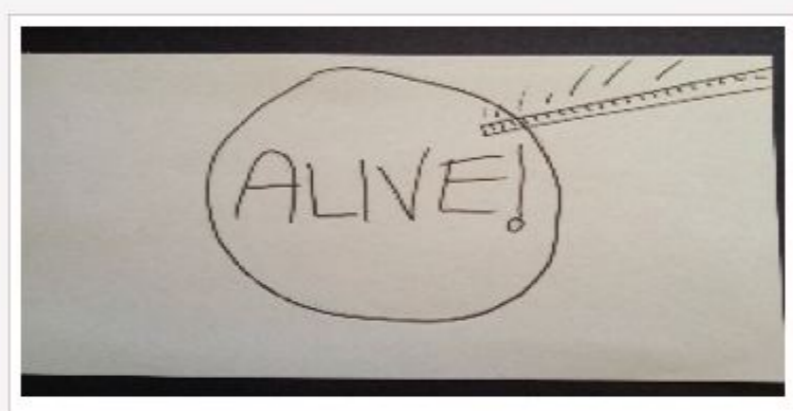

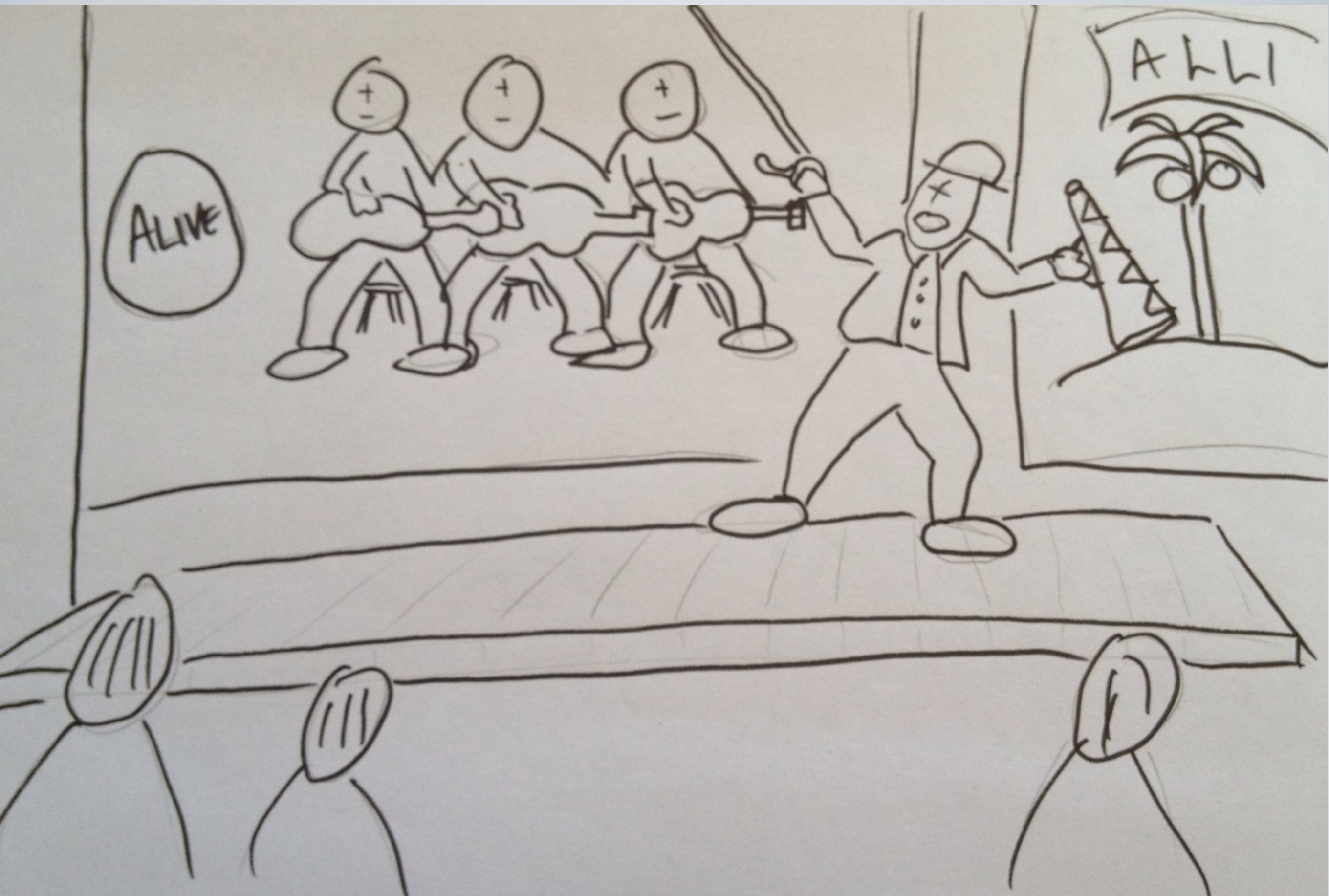

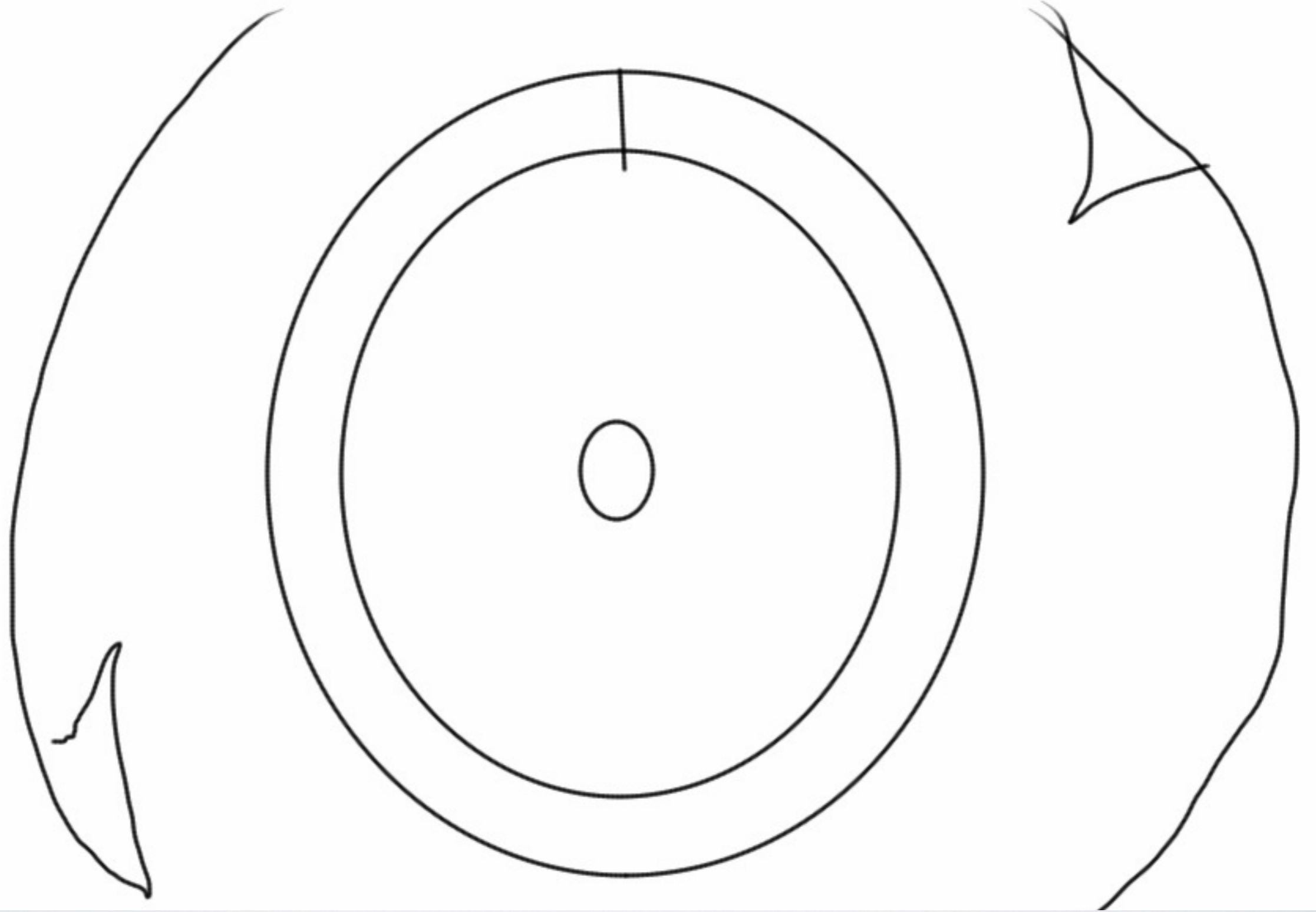

2.

EXT. BALLYHOO STAGE. DAY.

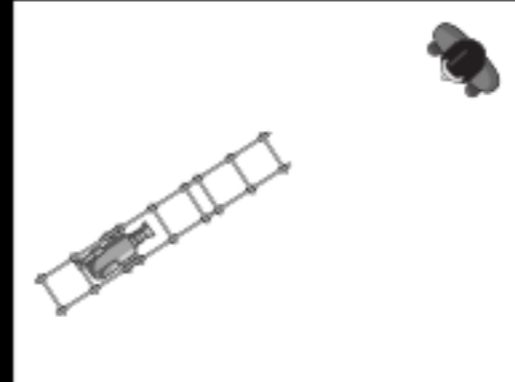
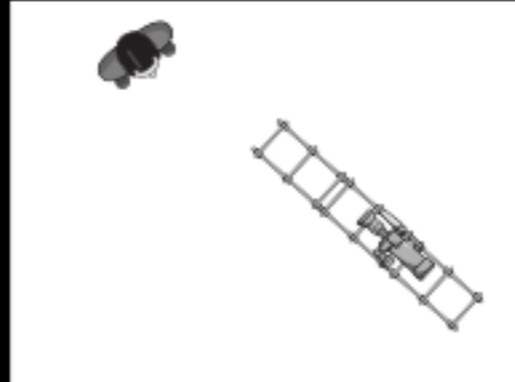

MASTER:
Born in Alabama from...

MEDIUM CLOSE UP:

WIDE:

VERY WIDE SHOT:



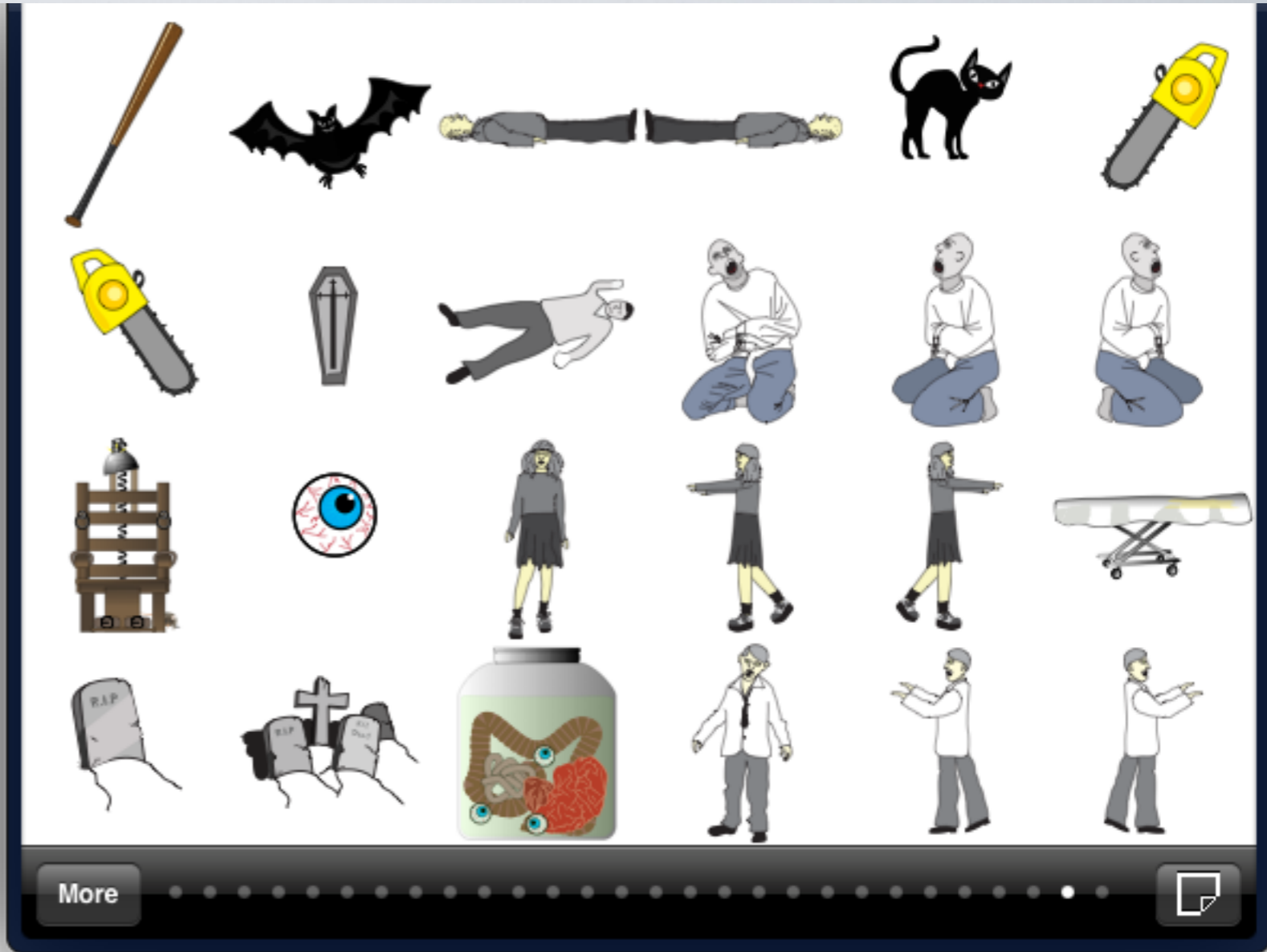

More







Done

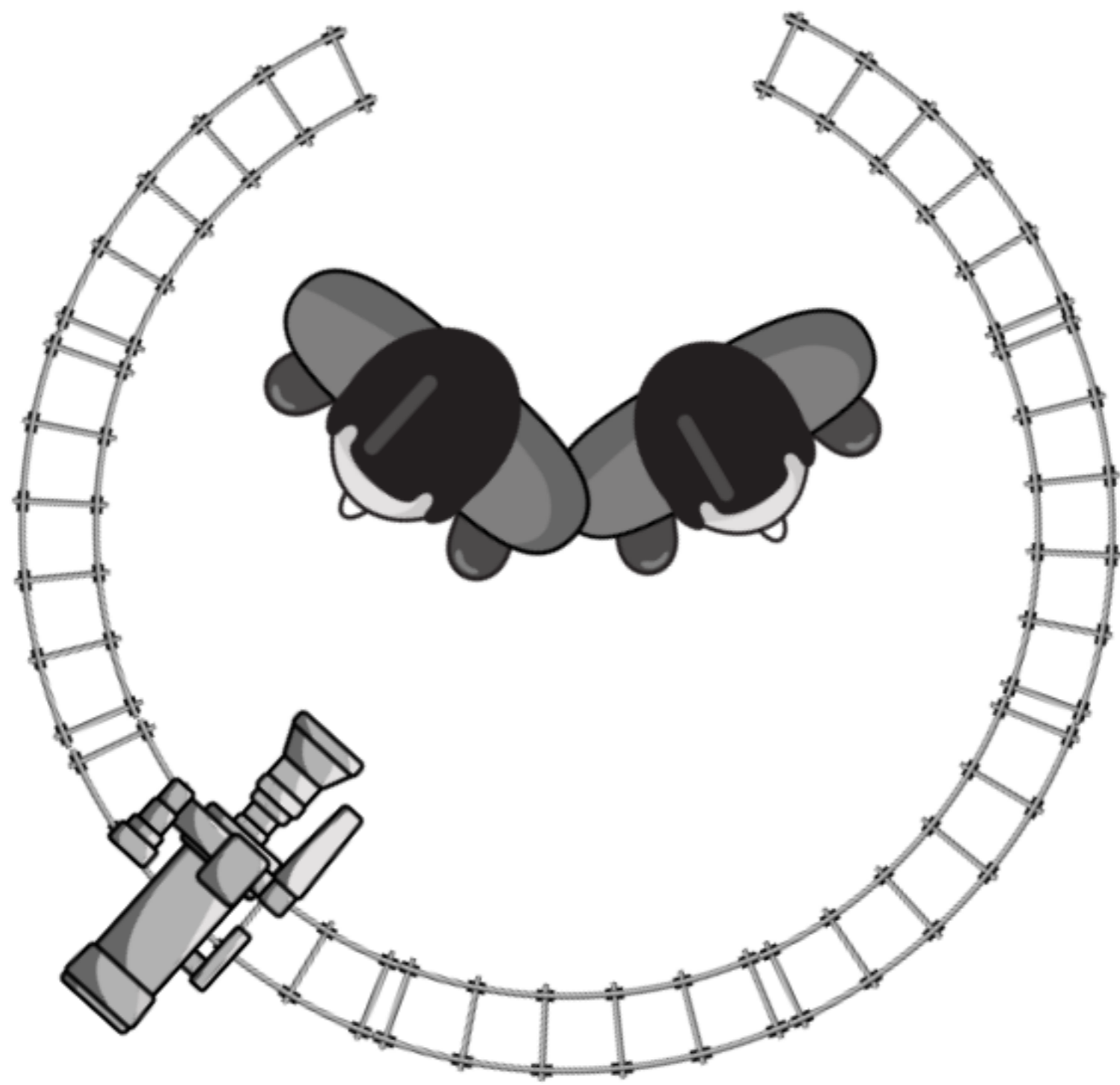



- Project Library**
- Alligator Man
 - Master Catalog (37)
 - Storyboard
 - Sketch
 - Screenplay
 - Calendar
 - Production Schedule

#	I/E	Setting	D/N	Eighths	Script Day	Location	Scheduled	Completed
1	EXT	DOCK. DAY						
2	EXT	BALLYHOO STAGE. DAY						
3	INT	SIDESHOW PIT. DAY						
4	EXT	BALLYHOO STAGE. DAY						
5	EXT	DOWNTOWN. DAY						
6	EXT	VAN/OUTPORT NEWFOUNDLAND. DAY						
7	EXT	FORTUNE GAME. DAY						
8	EXT	BALLYHOO STAGE. DAY						
9	INT	GARD GAME. DAY						

Month
 Week
 Day

Start of Shooting: [2011-12-16](#)
 End of Shooting: [2011-12-25](#)

Moving
 Day Off

December 2011 Calendar Weeks 48-52

Monday	Tuesday	Wednesday	Thursday	Friday	Saturday	Sunday
28	29	30 Nov	1 Dec	2	3	4
5	6	7	8	9	10	11
12	13	14	15	16	17	18
19	20	21	22	23	24	25
26	27	28	29	30	31 Dec	1 Jan

Production Schedule Details:
 Friday, Dec 16: Start of Shooting, 5:30 PM Crew Call, 6:00 PM Wheel of Fortune, 6:30 PM Milk Bottles, 7:00 PM Twins Caught
 Saturday, Dec 17: 8:30 AM Crew Call, 9:00 AM Alligator, 12:00 PM Lunch, 1:00 PM Conjoined Twins, 3:00 PM Strong Woman
 Sunday, Dec 18: 8:30 AM Crew Call, 9:00 AM Into., 11:00 AM Conjoined Twins, 12:30 PM Lunch, 1:30 PM Strong Woman
 Sunday, Dec 25: End of Shooting

<p>16</p> <ul style="list-style-type: none"> Start of Shooting 5:30 PM Crew Call 6:00 PM Wheel of Fortune 6:30 PM Milk Bottles 7:00 PM Twins Caught 	<p>17</p> <ul style="list-style-type: none"> 8:30 AM Crew Call 9:00 AM Alligator 12:00 PM Lunch 1:00 PM Conjoined Twins 3:00 PM Strong Woman 	<p>18</p> <ul style="list-style-type: none"> 8:30 AM Crew Call 9:00 AM Into. 11:00 AM Conjoined Twins 12:30 PM Lunch 1:30 PM Strong Woman
<p>23</p>	<p>24</p>	<p>25</p> <ul style="list-style-type: none"> End of Shooting
<p>30</p>	<p>31 Dec</p>	<p>1 Jan</p>





The Celtx Forum

Here you can post questions regarding Celtx.

Search... Search
Advanced search

[Board index](#)

∨ A ^

[FAQ](#) [Register](#) [Login](#)

It is currently Mon Nov 28, 2011 2:30 pm

[View unanswered posts](#) • [View active topics](#)

COMMUNITY FORUMS		TOPICS	POSTS	LAST POST
	General Discussion Talk about scripts, movies, writing, what you had for breakfast... Just about anything goes, except SPAM! Moderators: Sharkey, Sheila , ntay, vedus hate	3898	37122	by Daniel Mon Nov 28, 2011 8:25 am
	Script Reviews & Collaboration Looking for feedback or assistance on your Celtx project? Post a link here for community review. Moderators: Sharkey, Sheila , ntay, spick , vedus hate	1908	11662	by Krusz Mon Nov 28, 2011 2:11 pm
	Script Competitions A forum for friendly and fun script writing competitions. Moderators: Sharkey, Sheila , ntay, vedus hate, oddjob	244	2045	by dollun Fri Nov 25, 2011 10:20 am
	Celtx International This forum is for all things international.... link to celtx reviews from other countries, participate in the development of celtx / Firefox localization, or just tell us where you're from. Moderators: Sharkey, Sheila , ntay, vedus hate	306	887	by kwadil Fri Nov 25, 2011 5:21 am

SUPPORT FORUMS		TOPICS	POSTS	LAST POST
	News and Announcements General News and Announcements regarding the Celtx. Moderators: Sharkey, Sheila , ntay, spick , mgk , vedus hate	316	1752	by spick Tue Nov 22, 2011 1:16 pm
	Celtx Q & A A place for general discussion and questions about using Celtx. Moderators: Sharkey, Sheila , ntay, vedus hate	2929	11314	by Daniel Mon Nov 28, 2011 9:43 am
	Celtx Studios This forum will answer all of your Studio related questions. Moderators: Sharkey, ntay	189	867	by spick Wed Nov 23, 2011 1:01 pm
	Mobile Apps The place to ask questions concerning Celtx mobile apps. Moderators: Sharkey, Sheila , ntay, spick , mgk , vedus hate	166	920	by spick Mon Nov 28, 2011 1:38 pm
	Features Suggestion An area where users can submit ideas for new features they would like to see implemented in Celtx. Moderators: Sharkey, Sheila , ntay, spick , mgk , vedus hate	1729	6818	by Phil Friel Sun Nov 27, 2011 8:00 am
	Modifying Celtx Developer tutorials and discussion forum Moderators: Sharkey, ntay, vedus hate	222	896	by Daniel Thu Nov 24, 2011 3:14 pm
	Report a Bug Submit and peruse bug reports here. Moderators: Sharkey, Sheila , ntay, spick , vedus hate	2841	12560	by spick Mon Nov 28, 2011 2:26 pm

PRODUCTION

- Access to information
- Clapboard
- Storyboard
- Script
- Internet Access?
- Contact Information

Digital HD Video Camera Recorder Caméscope numérique HD

Operating Guide

Before operating the unit, please read this manual thoroughly,
and retain it for future reference

The supplied CD-ROM includes Operating Guide for the HVR-V1 series.
(Japanese, English, French, German, Italian, Spanish, and Simplified Chinese
versions).

For more details, see "Using the CD-ROM Manual" on page 12.

Le CD-ROM fourni contient le mode d'emploi de la série HVR-V1
(en japonais, anglais, français, allemand, italien, espagnol et chinois simplifié).
Pour de plus amples renseignements, consultez la section « Using the CD-ROM
Manual » à la page 12.

HDV
HDV 1080i

DVCAMTM

Mini **DV** Digital
Video
Cassette

InfoLITHIUMTM **L**
SERIES

MEMORY STICKTM

HDMI

HVR-V1U/V1N



PRODUCTION

Secret Life of a Troll

EDIT INFO

SCENE

1

TAKE

Liam b

VIDEO/FILM FORMAT

H.264/1080p

SOUND FORMAT

DIRECTOR

Jamie Skidmore

DATE & TIME

CAMERA

PRODUCTION COMPANY









 133min
HDV1080i

STBY

0:31:50

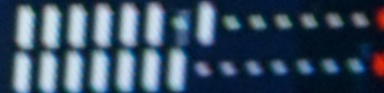

F2.8 0dB

L R 
60

POST-PRODUCTION

- Students issued iPads at admission to university
- Formal workshops made available to students and instructors
- Students purchase required books and apps

